



2016

# Products

## Portfolio

**"INTELLIGENCE & INNOVATION"**



SILICON CRAFT TECHNOLOGY CO.,LTD.  
WWW.SIC.CO.TH

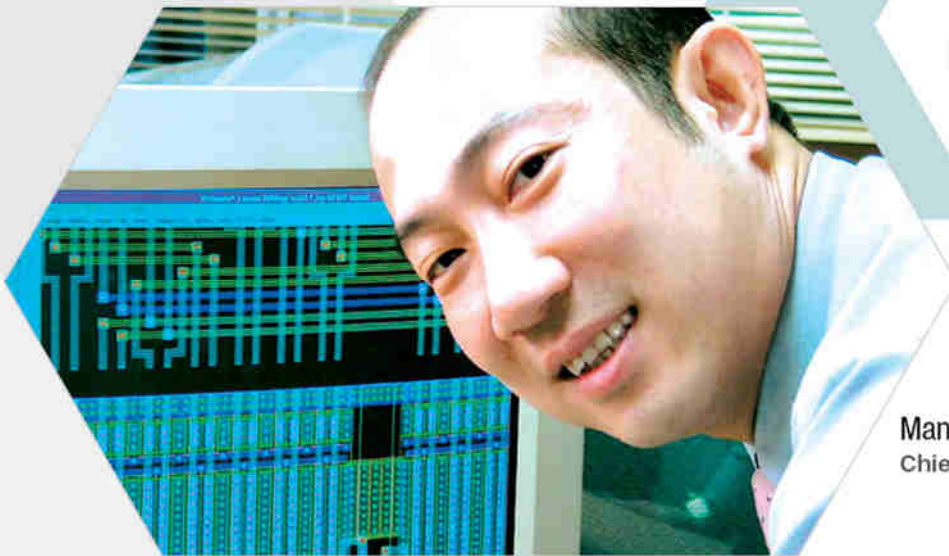

**Manop Thamsiriant**  
Chief Executive Officer

# Designer with taste for fabless chips



## About SIC

Established in 2002, SIC offers novel, custom and standard design microchips for RFID applications and delivers products that carry high-value added features and superior overall systems performance. The products' quality is endorsed by years of lasting partnerships. SIC's reputation has been further solidified through its experience and expertise in the design and development of world-class foundry semiconductor manufactures of linear and mixed-signal integrated circuits.

## What we stand for

We have been always persisting in the spirit of innovation, striving for excellence, upholding the quality of products that are compatible with the world's standard and regulations. **"Intelligence & Innovation"**, this is a large part of our identity. With this passion, we will continue to deliver high performance state-of-the-art products to our customers.

## ODM

Silicon Craft has over time developed the competitive and successful ODM transponders within a short turn-around time through its extensive and well established qualified list of subcontractors.

# COMPANY CORE COMPETENCIES

Strong and Healthy  
Business Model

13 Years IC Design  
Experience

## FULL-RANGE OF RFID PRODUCTS

Specialize in Mixed-signal and  
Low-power ASICs Design

Global Customer Network

WE NEVER COMPROMISE THE QUALITY  
OF OUR PRODUCTS AND SERVICES





# Table of contents

## NFC FAMILY

- NFC Transponder IC with UART and GPIO Interface  
SIC4310/ SIC4311

PAGE 5

- ISO14443A Ultralight Ticket IC
- Contactless Smart Card IC with  
“Proprietary Crypto Pair”

SIC43U1

SIC43C2/ SIC43C2F

PAGE 8-9

- NFC Transponder IC with Configurable  
Memory-size and RF Field Detection

SIC43N1/ SIC43N1F

PAGE 7

- NFC Development Kits
- NFC Comparison Table

PAGE 10-11

## READER ICs

- Multiprotocol HF RFID Reader IC

SIC9410

PAGE 12

- 13.56-MHz Multistandard Reader IC

SIC9311

PAGE 13

- 13.56-MHz ISO14443A RFID Reader IC

SIC9100

PAGE 14

- Reader IC Comparison Table

PAGE 15

## ANIMAL ID TRANSPONDER ICs

- Ultra-FDX Transponder IC

SIC7888

PAGE 16

- Ultra-HDX Transponder IC

SIC7999

PAGE 17

## UHF TRANSCEIVER IC

- UHF Transceiver IC with Low Power RF Wake-up  
Mode

SIC8360

PAGE 18

## AUTOMOTIVE FAMILY

- The LF FDX Automotive Glass Transponder IC with  
128-bit AES Encryption
- The Encrypted Low-frequency FDX Automotive Glass  
Transponder IC

XES128F

TM-01/TN-01

PAGE 19-20

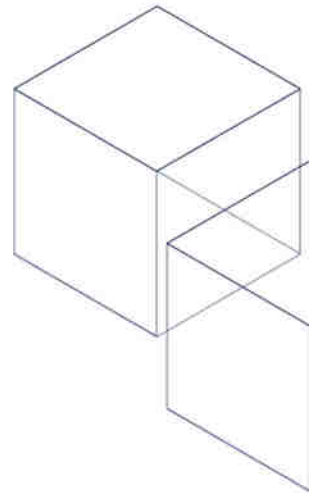

PACKAGE



Die wafer



Die with AU bump



QFN



DFN

# NFC TRANSPONDER ICs

## NFC Transponder IC with UART and GPIO Interface

### SIC4310 / SIC4311

The SIC4310 is a passive NFC Type 2 Tag IC with the UART and GPIO interface. It features battery-less operation which is able to harvest power from NFC devices at up to 10mA and allows the external devices to operate passively.

The SIC4311 is a special version of transponder IC designed for battery-operated devices. With its added feature of a 40nA standby current, the SIC4311 can enable portable devices to extend their battery life by up to 15%.

### Highlight Features

- Write/read through NFC smartphone/ NFC or RFID reader device
- Direct data transfer from RFID to UART or vice versa
- Operating from either RFID power or external DC
- 3.3-V On-chip regulator for power harvesting mode
- Up to 10 mA sourcing capability to power external circuit  
(Depending on harvested power from RF)
- Compatible with NFC Forum Type 2 Tag
- $\pm 2\%$  1.8432 MHz on-chip factory-trimmed oscillator

### Interface and Peripheral

- RF interface based on ISO14443A - 106 kbps
- UART interface speed from 9600 to 115200 bps
- UART interface with hand-shaking option
- Activity indicator pins
  - RF detect
  - RF busy
  - Reserve power is ready

### Memory

- 228 bytes EEPROM accessible from RF and UART
- 196 bytes user memory
- EEPROM organization enabling NDEF format
- EEPROM erase/write cycle up to 100,000 times
- EEPROM memory retention up to 10 years at 70°C
- 2 x 64-byte deep FIFO for UART data transfer - TX/RX



## Applications

- Firmware upgrade via NFC
- NFC bridge for embedded systems
- NFC enabled sensors
- Metering/ vending machines
- Interactive posters
- Smart home appliances
- Wireless industrial machine interface
- Smart toys

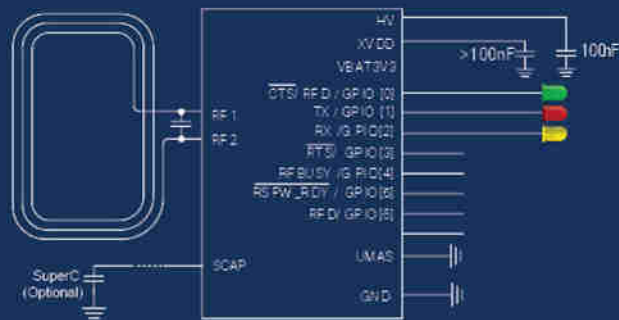

SIC4310 Basic configuration with LED Indicator

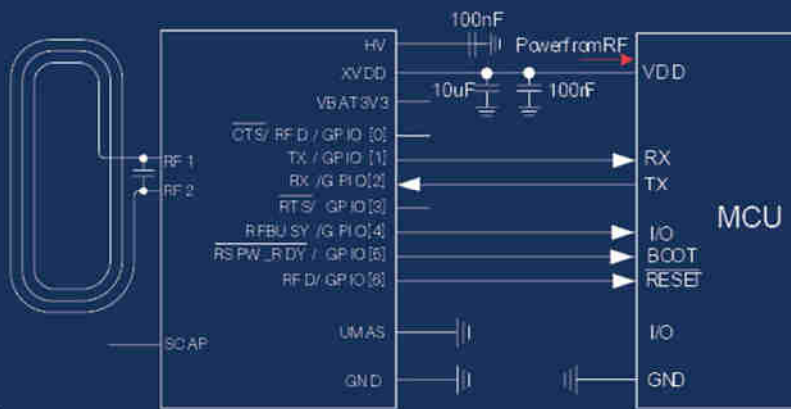

SIC4311 RF-powered configuration for firmware upgrade  
(Power harvesting)

Available **packaging**



Scan to discover



# NFC Transponder IC with Configurable Memory-size and RF Field Detection

## SIC43N1 / SIC43N1F

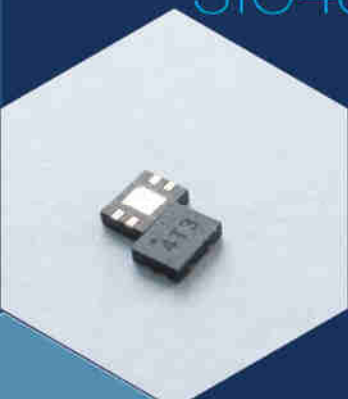

The SIC43N1 is an NFC Type 2 Tag IC with NDEF-supported and memory-size configuration (144/ 888/ 944 bytes). SIC43N1 provides security features such as password protection and a limitation on password guessing.

In addition, the SIC43N1F comes with a RF field detection pin which can generate signals to "wake up" another device from its sleep mode when the RF field is in close proximity.

The RF field detection pin can also be configured as a tamper detection pin as a safeguard against tampering attempts.

### Highlight Features

- NFC-Forum Type 2 tag with RF field detect pin
- Write/Read through NFC /RFID-reader device

### Interface

- RF interface based on ISO14443A - 106 kbps
- True anti-collision
- Configurable RF field detect output :
  - 1.8V output
  - Open-Drain
  - Automatic detection

### Memory

- 7-byte UID / 4-byte NUID (optional)
- Configurable memory size in 1 of 3 modes
  - Mode 1 : 888 bytes ( delivery format )
  - Mode 2 : 944 bytes
  - Mode 3 : 144 bytes
- EEPROM organization enabling NDEF format
- EEPROM erase/write cycle up to 100,000 times
- EEPROM memory retention up to 10 years at 70°C

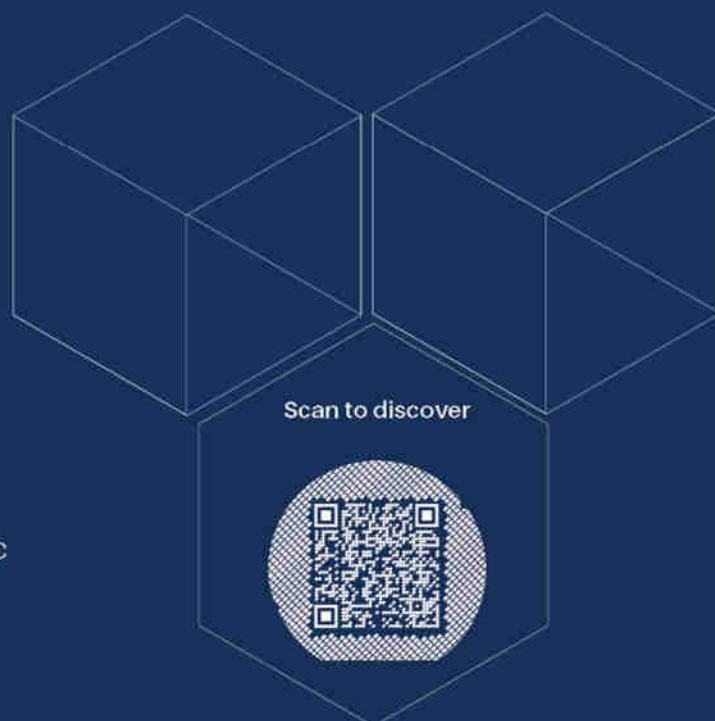



## Applications

- Print media
- Connection handovers
- Bluetooth or Wi-Fi pairing
- Tamper-detection labels

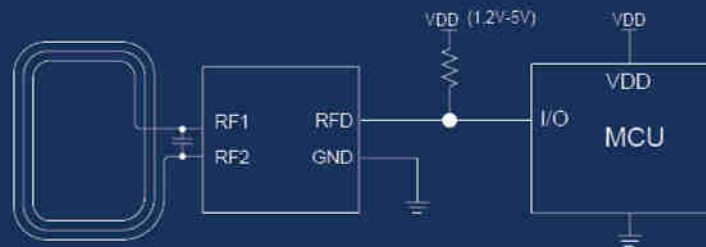

SIC43N1F with RF detect pin operating in open-drain mode

Available **packaging**



## ISO14443A Ultralight Ticket IC

### SIC43U1

The SIC43U1 is an NFC Type 2 Tag IC with 144 bytes memory and conforms to the ISO14443A RF interface. It features password protection and is able to provide a locking function to each data block.

## Highlight Features

- Fully passive operation
- True anti-collision for multiple card presenting
- Memory organization is similar to the widely used conventional contactless single ticket and smart label in the market

## Applications

- Tickets
- Smart labels
- Contactless cards



# Contactless Smart Card IC with “Proprietary Crypto Pair”

## SIC43C2/ SIC43C2F

To serve proprietary encryption, such as access control, security card and closed-loop applications, the SIC43C2 highlights “SP-Crypto” encryption (Silicon Craft proprietary encryption), that is paired with the SIC9410 (Multiprotocol RFID Reader IC). With this proprietary, the information security of the tags can be reached to another higher level.

The SIC43C2F is another version that includes an RF field detection pin.

### Highlight Features

- Fully passive operation
- Silicon Craft’s proprietary encryption “SP-Crypto”, works in pair with reader IC SIC9410 to increase the security of the specific system

### Interface

- RF interface based on ISO14443A - 106 kbps
- True anti-collision
- RF read distance up to 10 cm (up to an antenna and reader settings)

### Memory

- 7-byte UID or 4-byte NUID
- 1k-bytes EEPROM
- Memory organization: 64 blocks, 16 sectors (4 blocks/ sector)
- EEPROM erase/write cycle up to 100,000 times
- EEPROM memory retention up to 10 years at 70°C

### Applications

- Smart cards
- Access control systems
- Closed-loop systems
- Smart toys & games

Available **packaging**



# NFC DEVELOPMENT KITS

## SIC4310 Development Kits

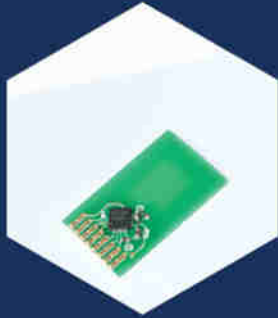

### SIC4310-MC

A 12.5 x 19.7 mm tiny module with a UART interface and 4 GPIOs.



### SIC4310-USB

A 12.5 x 37.3 mm tiny module with a USB interface.



### SIC4310-HV

A harvesting module with a UART interface and 3 GPIOs. The on-board inductive antenna can harvest a current up to 10 mA.



### SIC4310-HVU

A harvesting module featuring UART or USB interface and two LEDs that can be controlled via GPIO pins. The on-board inductive antenna can harvest a current up to 10 mA.

### SIC4310-FU

Ready-to-use kit featuring ARM Cortex M0 MCU, SIC4310, LCD, inductive antenna, two function buttons, temperature sensor, connectors (I2C, SPI, UART, programming and debugging).



Scan to discover



# COMPARISON TABLE



PRODUCT NAME	STANDARD	INTERFACE	COMMUNICATION SPEED	USER MEMORY SIZE (EXCLUDE CONFIG.) (BYTES)	DATA FORMAT	SECURITY FEATURE		POWER SUPPLY			POWER CONSUMPTION		INTERNAL RESONANCE CAPACITOR	PACKAGE		
						INPUT	OUTPUT	INPUT	OUTPUT	INPUT	OUTPUT	INPUT		OUTPUT	INPUT	OUTPUT
DUAL-INTERFACE NFC TRANSPONDERIC	ISO14443A	NFC Type 2 Tag	UART (TX-RX pair)	196	User Memory	•	•	10mA	6mA	6mA	80uA	187uA	17pF	•	•	•
	SIC4310	•	GPIO		106	NDEF Support	•	•	10mA	6mA	6mA	40nA	187uA	30.3pF	•	•
NFC TRANSPONDERIC	SIC4311	•	RF Field Detection	115	Password	•	•	6mA	6mA	6mA	•	•	50pF	•	•	•
	SIC43N1	•	Tampering- sensor	196	SP- crypto	•	•	8mA	20uA	•	•	•	Pin Count	•	•	•
CONTACTLESS TICKET/ LABEL IC	SIC43N1F	•	RF (kbit/s)	144/888/944	Power from RF Field	•	•	•	•	•	•	•	DFN	•	•	•
	SIC43U1	•	UART (kbit/s)	144/888/944	External Supply 3.3V	•	•	•	•	•	•	•	QFN	•	•	•
CONTACTLESS SMART CARD IC	SIC43U1	•	RF (kbit/s)	48	Harvesting Output Current at XVDD Pin(max)	•	•	•	•	•	•	•	DOW	•	•	•
	SIC43C2	•	UART (kbit/s)	752	GPIO Output Sinking Current / Pin(max)	•	•	•	•	•	•	•	Die with AU Bump	•	•	•

• The RF field detection pin function can be programmed to RF field detection or tampering sensor

• Available now  
 • Not fully supported in NDEF dynamic lock configuration

• External supply is connected to VBAT3V3 pin  
 • In-development



# READER ICS

## Multiprotocol HF RFID Reader IC

### SIC9410

A new generation of multiprotocol reader IC, provides a hi-speed SPI controller/host interface with a built-in 64-byte FIFO for smooth data transfer. SIC9410 is suitable for mid-range application e.g. PC-based desktop reader, handheld reader, library system, and access control system.

### Highlight Features

- ISO 14443A/B, FeliCa (air protocol only)
- All NFC tag types and ISO15693
- Maximum transmitter current up to 300 mA
- 256-byte EEPROM
- 5.5 uA in 'power down' mode



**Pi941**  
**Multiprotocol Reader**  
 Proprietary reader module for  
 SIC9410, SIC9311 and SIC9100 ICs

### Interface and Peripheral

- SPI interface up to 10 Mbps
- 64-byte send and receive FIFO-buffer
- User-configurable registers
- 112-byte EEPROM
- Interrupt (IRQ) PIN
- Programmable timer
- Programmable clock divider for external MCU
- Low jitter on-chip oscillator buffer
- On-chip dual 80 mA 3.3V regulators

### Applications

- Contactless payment systems
- Access control systems
- PC peripheral devices
- Handheld RFID readers

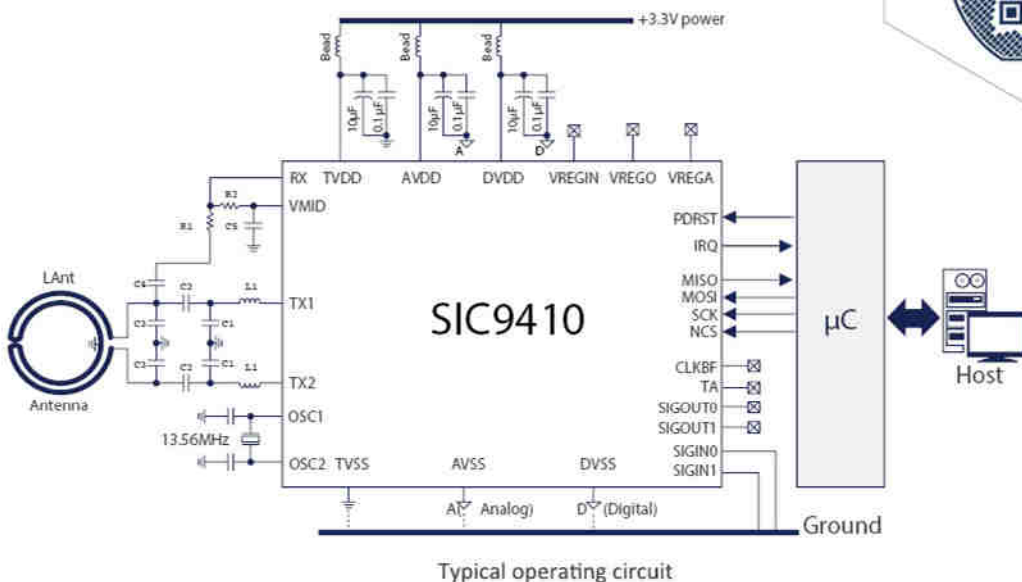

Scan to discover



## 13.56-MHz Multi-Standard Reader IC

# SIC9311

SIC9311 is a single-chip long-ranged reader IC for all major 13.56MHz RFID standards. SIC9311 provides a hi-speed SPI host interface with a built-in 64-byte FIFO for supporting high-speed transaction. Furthermore, SIC9311's long read distance performance based on its high-current transmitter and low-sensitivity receiver, which can ensure each transaction is always be processed completely.

## Highlight Features

- ISO14443A and B (all bit rates), NFC type 1, 2,4 tags and ISO15693
- Outstanding read range with maximum transmission current up to 300mA
- On-chip framing codec and framing handler with high noise immunity
- 256-Byte EEPROM
- Power consumption is only 5.5uA in power down mode

## Interface and Peripheral

- SPI interface up to 10 Mbps
- 64-byte send and receive FIFO-buffer
- 64-byte addressing
- User-configurable registers
- 256-byte EEPROM
- Interrupt (IRQ) PIN
- Programmable timer
- Programmable clock divider for external MCU
- Low jitter on-chip oscillator buffer
- On-Chip dual 80 mA 3.3V regulators

## Applications

- Access control systems
- PC peripheral devices
- Handheld RFID readers
- NFC tag readers

### Pi941 Multiprotocol Reader

Proprietary reader module for SIC9410, SIC9311 and SIC9100 ICs



Available **packaging** 

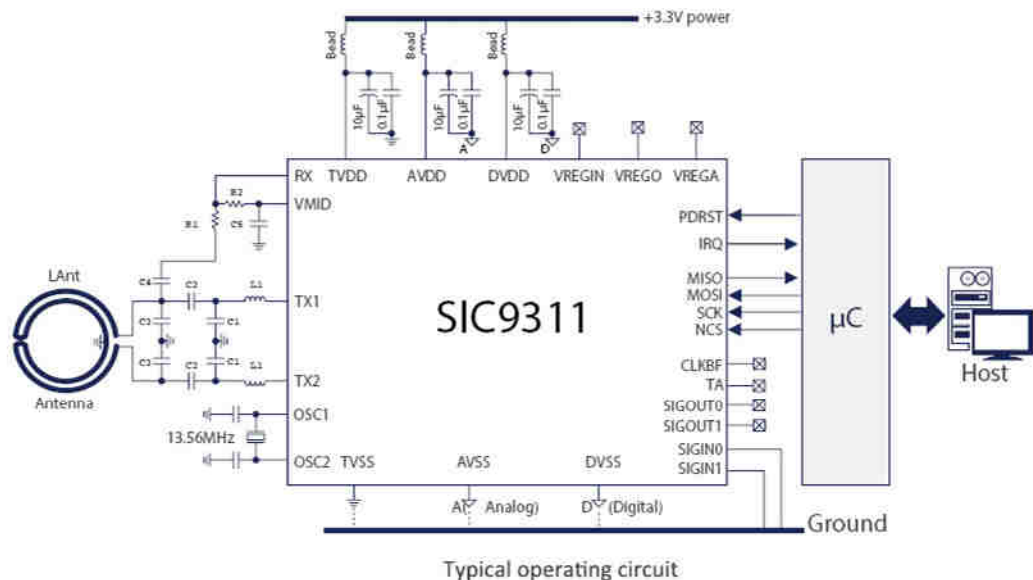

## 13.56-MHz ISO14443A RFID Reader IC

# SIC9100

SIC9100 is the new generation of contactless reader IC which supports secure card and mobile with Near Field Communications (NFC), which based on ISO14443A standard. The SIC9100 is highly suitable for various applications especially handheld RFID reader, secure access control and door lock. The SIC9100 equipped with built-in frame decoder to smooth the integration, reduce external components to make the devices compact, reliable and competitive.

### Highlight Features

- ISO14443A (all bit rates), NFC type 1, 2 and type 4 tags
- Outstanding read range with maximum transmission current up to 200mA
- 1mVpp receiver sensitivity
- On-chip framing codec and framing handler
- 256-Byte EEPROM
- Power consumption is only 5.5uA in power-down mode

### Interface and Peripheral

- SPI interface up to 10 Mbps
- 64-byte send and receive FIFO-buffer
- User-configurable registers
- Interrupt (IRQ) PIN
- Programmable timer
- Programmable clock divider for external MCU
- Low jitter on-chip oscillator buffer
- On-chip dual 80 mA 3.3V regulators

Available **packaging**



### PI941 Multiprotocol Reader

Proprietary reader module for SIC9410, SIC9311 and SIC9100 ICs

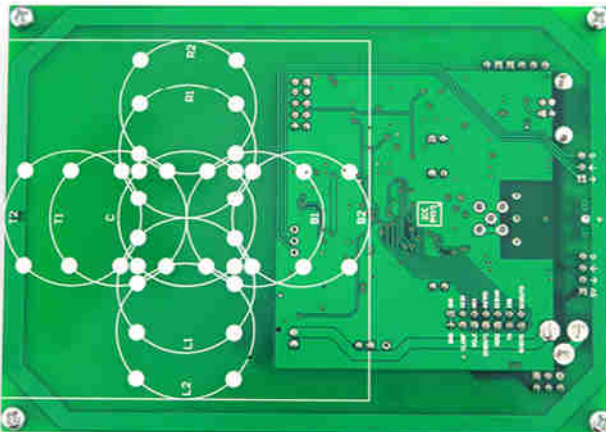

### Applications

- Contactless payment systems
- Secure access control cards
- PC peripheral devices
- Handheld RFID readers

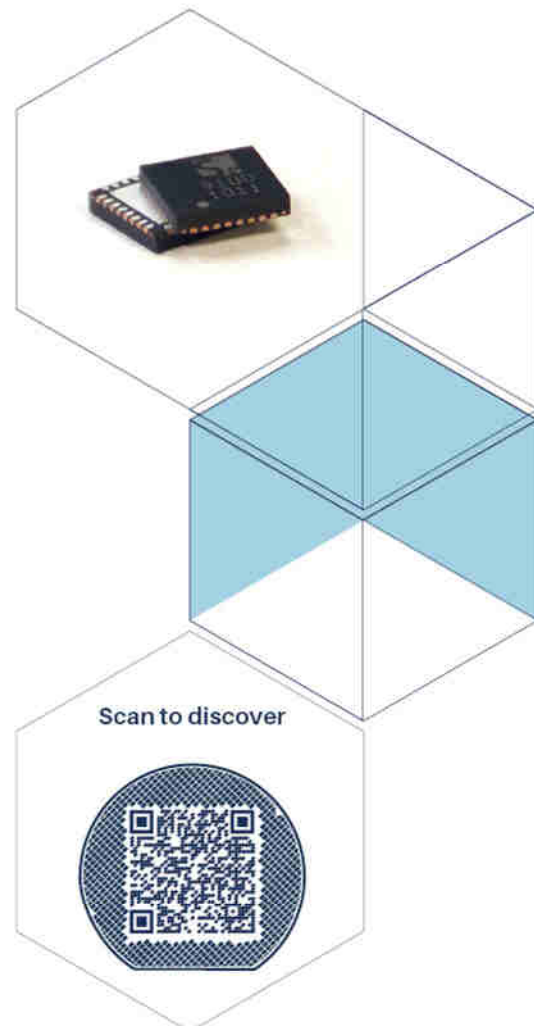



# COMPARISON TABLE

	Protocol	Feature		Specification			Application								
				READ DISTANCE (CM)	Maximum Power Consumption (uA)	Transmission Current (mA) @5V	EEPROM (byte)	Package	Contactless Payment System	Secured Access Control	PC Peripheral Device	Handheld RFID Reader	Mid Range/Desktop Reader		
SIC9410	ISO14443A (TYPE A, 433) - 106212/2424/48 Kbps ISO14443B (TYPE B, 433) - 106212/2424/48 Kbps	●	●	●	●	●	●	●	QFN32/ TSSOP28	●	●	●	●	●	●
SIC9311		●	●	●	●	●	●	●	QFN32/ TSSOP28	-	●	●	●	●	●
SIC9100		●	●	-	-	-	-	-	QFN32/ TSSOP28	10 20 8 200 256	-	●	●	●	●

Remark

#1 #2

#1 \*Pi-931-X34CC

#2 Soft power down mode

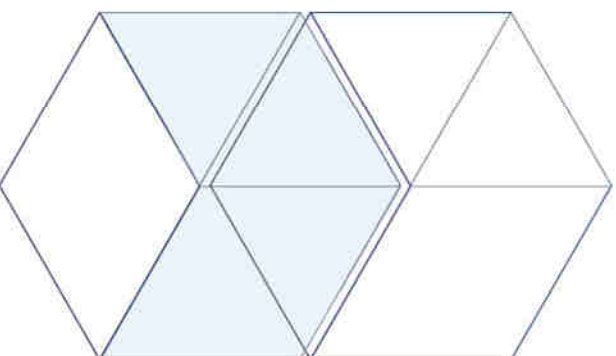



# ANIMAL ID TRANSPONDER ICs

## Ultra-FDX Transponder IC

### SIC7888

SIC7888 is read/write low frequency FDX RFID microchip intentionally designed to maximize the read range. The on-chip 1184-bits EEPROM allows additional information to be stored for custom user applications or on-site database. The chip contains 32-Bit unique identification number for anti-collision and 64-bits traceability data for optional identification.

### Highlight Features

- Best read range performance by SIC's C-boost technology
- Compatible with ISO11784/85 animal ID data structure
- Resonant and fine-tuning capacitor array on chip
- Anti-collision support
- Two level of password authorizations
- Low power consumption

### Memory

- 1408 bits (44 x 32) EEPROM
- 1184 bits (37 x 32) in user memory area
- More than 100,000 erase/write cycles
- 10 years non-volatile data retention
- Secure memory lock functionality
- 32 Bit unique identification number (UID)
- 64 bit traceability data

**SIC7888 tuner**  
(SIC proprietary)



### Applications

- Livestock management
- Animal identifications
- Automation industries
- Item tracking systems
- Logistic management
- Access control systems
- Vending machines
- Sport systems

Available **packaging**

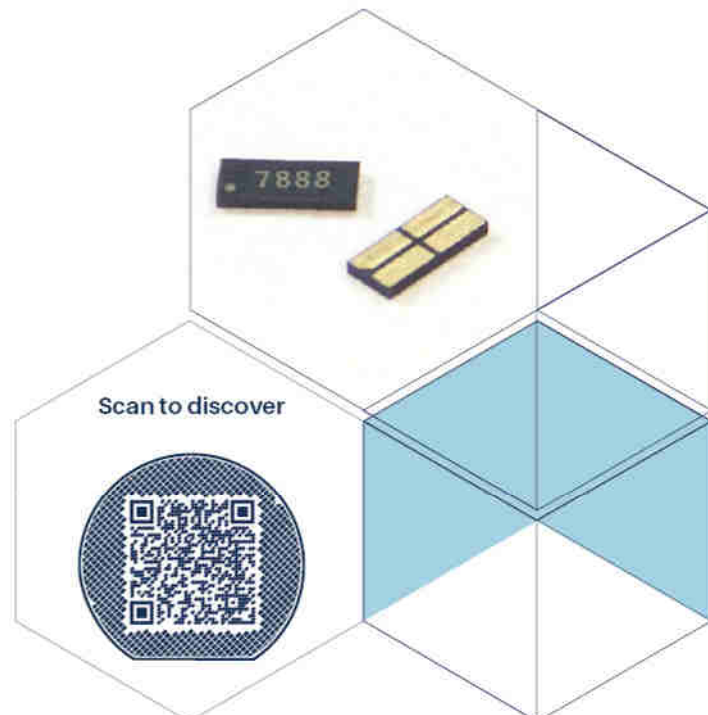

## Ultra-HDX Transponder IC

### SIC7999

SIC7999 is a fully integrated RFID ASIC by using half-duplex transmission for advanced animal electronic tagging transponders. The device in read-only mode is fully compliant with the ISO 11784/ 11785 HDX animal RFID data protocol and structure. With the exclusive 'Energy Harvesting' technique, SIC7999 has increased 15% in read range compared with the previous SIC7900 product.

### Highlight Features

- Standard and advanced animal R/W RFID transponder tags
  - Long read range transponder
  - On-chip resonant capacitor
  - On-chip tunable capacitor
- Half duplex FM telegram fc: 124/134 kHz contactless read/write data
- Small die size, suitable for implantable 2.0mm glass tags
- Compatible with ISO11784/11785 animal ID data structure
- Prevent chip-cloning
- Unique ROM ID (UID)
- Memory retention > 20 years

### Memory

- R/W user data memory of 6X32 (192 bits) for database management
- Support users access to factory with unique ROM ID (UID), prevent chip- cloning
- Write endurance > 100,000 R/W cycles
- Memory retention > 20 years
- Direct access/write mode
- Protect direct access/write mode
- Read-only system for animal ID without receiving command
- Read/write or OTP configuration
- Support cascade commands
- Comprehensive error logging reports



SIC7999 ID reader  
(SIC proprietary)

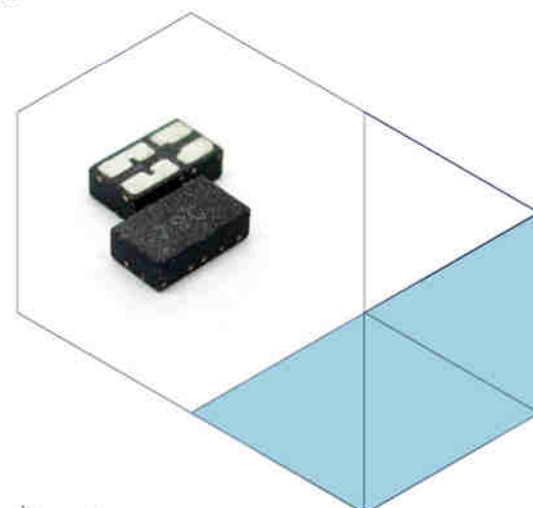

### Applications

- Animal tracking systems
- Food traceability
- Waste management systems
- Industrial management

Available **packaging**

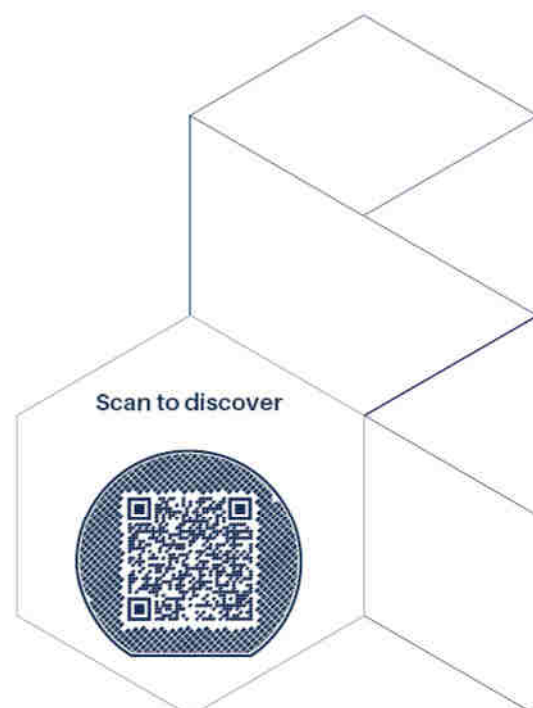

# UHF TRANSCEIVER IC

## UHF Transceiver IC with Low Power RF Wake-up Mode

### SIC8630

The SIC8630 is an UHF transceiver IC. It is designed to meet the lowest-power consumption by using RF wake-up receiver, which allows any battery-operated devices with this built-in SIC8630 to retain the lowest power standby mode. Moreover, the SIC8630 will wake the microcontroller unit up when it receives the wake-up signal ONLY. This product is suitable for the application needs the sniff interval of 1 second and consumes less than 2uA.

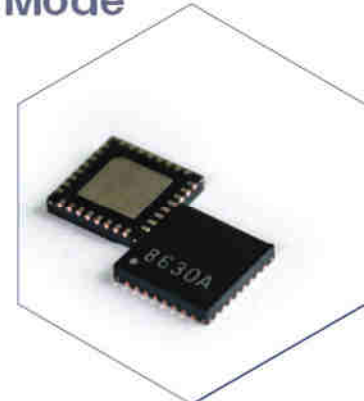

### Highlight Features

- Design to meet longest battery life (>5yrs) for midrange communication
- 2uA power consumption in RF sniff mode
- Automatic antenna tuning
- Programmable multichannel ISM bands 433/868MHz

### Applications

- Walk-THRU access control
- Asset tracking
- Home automation systems
- Health care

### Feature Summary

- Ultra low power wake-up receiver (OOK): 1mA @ -60dBm sensitivity
- Ultra low power RF sniff mode: 2uA for sniff interval of 1s
- Digital antenna tuning
- Digital XTAL tuning
- Programmable multi-channel ISM bands 868/433MHz
- Highly data integrity with data packet handler
- Programmable data rate up to 100kbaud
- Programmable RF output power (-30 to -4dBm)
- 5.7mA Tx mode, -4dBm (OOK/FSK)
- 2mA Rx mode, -60dBm sensitivity (OOK)
- Low sleep current, data retained (800nA)
- Operating voltage 2.4-3.6 V (suitable for standard coin cell battery 3V)
- SPI interface
- Separated 128 Byte Tx and Rx FIFO

Available **packaging**

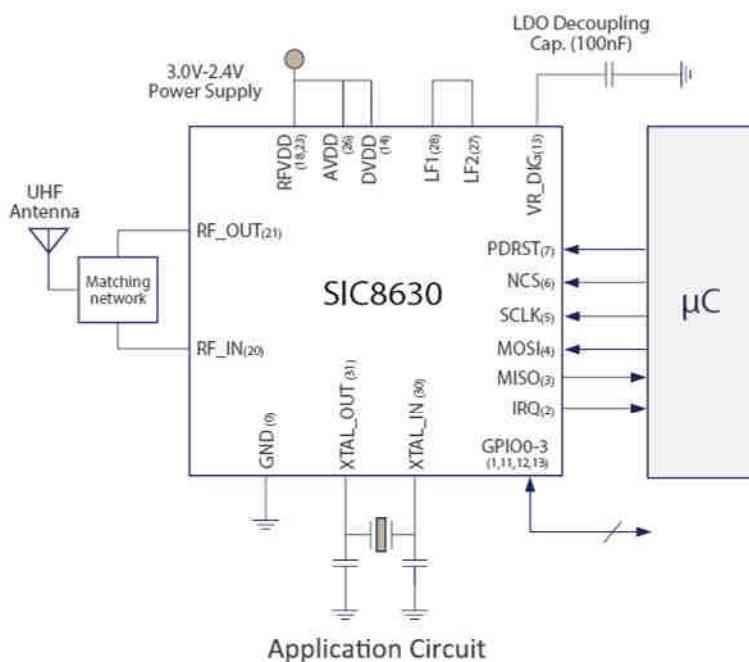

Scan to discover





# AUTOMOTIVE FAMILY

## The LF FDX Automotive Glass Transponder IC with 128-bit AES Encryption

### XES128F

The XES128F is the highest security LF FDX transponder IC, which integrated AES128-bit with SIC proprietary protocol. The XES128F performs 128-bit mutual authentication. The memory can be accessed and written by SIC proprietary protocol with unencrypted or encrypted telegram (optional). The encrypted telegram is implemented in order to increase security of read/write operation.

The XES128F memory organizes in 3 parts: (A) 32-bit unique ID which is arranged by manufacture and prohibits user from changing, (B) 128-bit AES Secret key which uses for AES encryption process and also encrypts the communication protocol, and (C) 128-bit R/W user memory.

The XES128F is integrated the on-chip air-tunable capacitor, automatically tuning the transponder frequency to 125 kHz which covers  $\pm 10\%$  variation of production. Moreover, the package has small size which is suitable for implanting in 2.0-mm glass tag form factor.

### Highlight Features

- Low-frequency FDX transponder ideal for car immobilizer applications.
- 128-bit AES the highest security encryption R/W immobilizer
- Mutual authentication
- Encrypted communication (optional)
- On-chip resonant capacitor and calibration array
- Easy for production (cover  $\pm 10\%$  variation of antenna inductance)
- Small package size, suitable for implantable 2.0 mm glass tag
- Contactless and batteryless

Available **packaging**



### Applications

- DX immobilizer keys
- LF access control systems

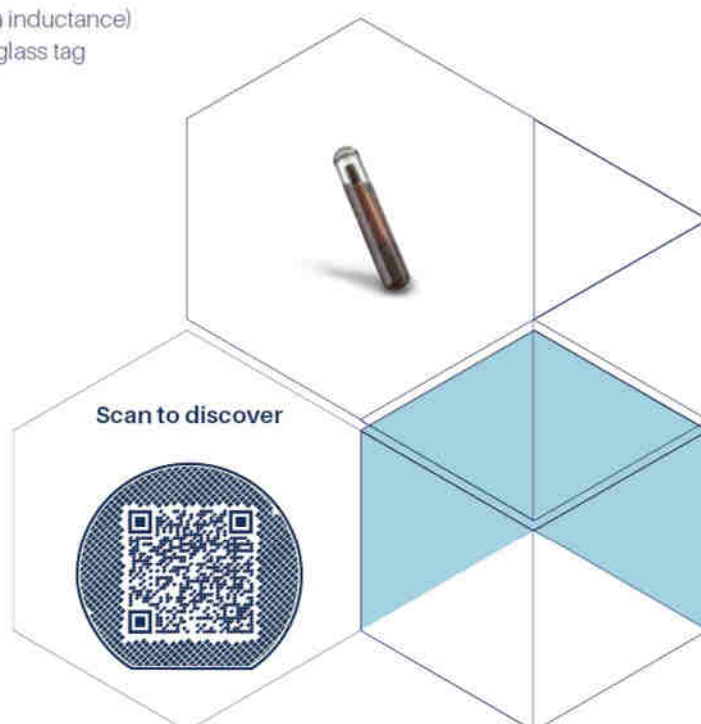



## The Encrypted Low-frequency FDX Automotive Glass Transponder IC

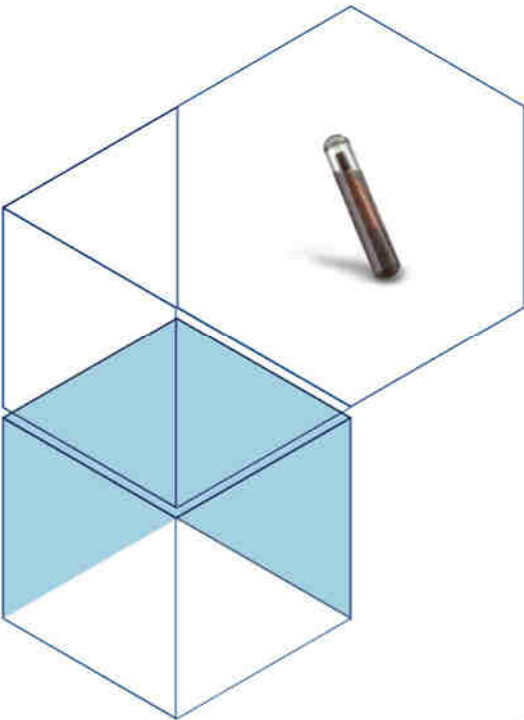

### TM-01/TN-01

The TM-01 and TN-01 are the encrypted low frequency FDX automotive transponder ICs, which adopted the advance technology from SIC.

TM-01 is the FDX encryption type, and fully compliant with M-2 transponder. It features 96-bit secret key, and 32-bit PIN code for the encryption. TN-01 is the fixed-code type, with 16-bit of password for security purpose instead.

TM-01 and TN-01 are provided with the ID programmable feature that can be operated by utilizing the general write command. Moreover, both of them are implemented with the on-chip capacitor for ensuring every single IC can perform well on the resonance frequency.

	<b>TN</b>	<b>TM</b>
<b>Tag Type</b>	Fixed-code	Encryption
<b>Communication Technology</b>	FDX	FDX
<b>Modulation</b>	ASK	ASK
<b>Data Encoding</b>	Manchester	Manchester
	Differential Bi-phase	
<b>Frequency</b>	130 kHz	125 kHz
	64/128-bit fixed code	Two-way authentication
	16-bit of password	96-bit of secret key 32-bit of PIN Code
<b>Data Rate</b>	RF/32	RF/32
	RF/40	
	RF/64	
<b>Memory</b>	128-bit of user memory (R/W)	96-bit of user memory (R/W)
	16-bit of device configuration (R/W)	32-bit of device Identification
	16-bit of password (write only)	32-bit of PIN (write only)
		96-bit of secret key (write only)
	Write endurance 200,000 R/W cycles	Write endurance 200,000 R/W cycles
	Memory retention > 20 years	Memory retention > 20 years

# ASIC DESIGN

SIC offers novel, high quality microchips and ASIC design service. With wealth of experience in the RFID technology,

we give customers the freedom to easily customize and modify existing designs, work with specific IP cores, using fewer resources to create new and exciting products in much faster design cycle. Over 150 man-year experiences in ASIC Design specialize in:

- Mixed-signal IC design
- Low-power IC design for automotive and biomedical
- Livestock identification
- NFC-enabled devices
- RF remote controller



## NFC APPLICATIONS DEMO



Sample of NFC product family

- SIC4310 NFC Monopoly
- SIC4310 NFC Batteryless WHAC-A-MOLE
- SIC4310 NFC Batteryless SparkBot
- SIC4310 NFC Batteryless E-ink
- SIC4310 NFC Batteryless Interactive Poster
- SIC4310 -Toy NFC Enabler Energy-harvested sound & LED control
- SIC43N1F NFC Bluetooth Paring

# SOFTWARE & SECURITY SUPPORT



## NFC Demo App by SIC

This application is used to demonstrate SIC4310 NFC Enabler development kits developed by Silicon Craft Technology Ltd. (SIC).



The Android SIC4310 demo application can be download from <https://play.google.com/store/apps/details?id=com.sic.demo&hl=en>

PI931 Demo Software  
SIC7888 AIR Tuner  
SIC7999 ID Writer

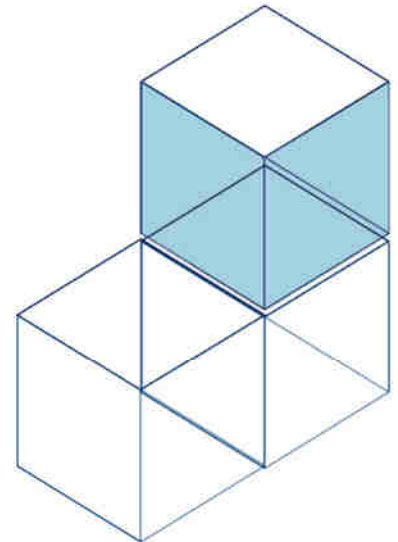

## PLEASE FOLLOW US



### On LinkedIn

Follow our news and events on LinkedIn



### On Youtube

Subscribe to our YouTube Channel for the demo videos



### On Twitter

Follow our news and events on Twitter



### Headquarters

40 Thetsaban Rangsan Nua Rd,  
Lat Yao,Chatuchak,  
Bangkok 10900 Thailand.

Tel : 66 (0) 2589 9991

Fax : 66 (0) 2 589 8881







SILICON CRAFT TECHNOLOGY CO., LTD.  
[www.sic.co.th](http://www.sic.co.th)